

# TRITON

## 8" - 10" Submersible Screw Centrifugal Pumps

### Materials of Construction:

#### Impeller/Casing/Inlet Manifold/ Back Pull-Out Plate/

#### Guide Bracket/Elbow:

..... Ductile cast iron.

Upper Cutter..... Cast steel, heat treated to minimum Rockwell C 60.

Mechanical Seal:..... Tungsten carbide.

Flange:..... 150 lb. ANSI rated.

Paint:..... Stainless Epoxy.

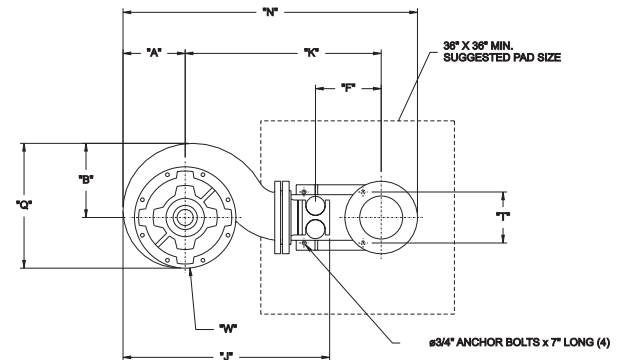

DRAWINGS AND DIMENSIONS SUBJECT TO CHANGE WITHOUT NOTICE. DO NOT USE FOR CONSTRUCTION PURPOSES. CONTACT VAUGHAN FOR CERTIFIED CONSTRUCTION PRINTS.

MODEL	A	B	C	D	E	F	G	H	J
SSC8X8B	11 <sup>9</sup> / <sub>16</sub>	13 <sup>13</sup> / <sub>16</sub>	8	13 <sup>1</sup> / <sub>8</sub>	8 <sup>1</sup> / <sub>4</sub>	12 <sup>3</sup> / <sub>16</sub>	6 <sup>7</sup> / <sub>8</sub>	18 <sup>1</sup> / <sub>4</sub>	38 <sup>3</sup> / <sub>8</sub>
SSC10X10C	15 <sup>15</sup> / <sub>16</sub>	18 <sup>11</sup> / <sub>16</sub>	10	15 <sup>3</sup> / <sub>4</sub>	10 <sup>1</sup> / <sub>4</sub>	14 <sup>3</sup> / <sub>8</sub>	8 <sup>11</sup> / <sub>16</sub>	18 <sup>11</sup> / <sub>16</sub>	47 <sup>3</sup> / <sub>4</sub>

MODEL	K	N	P	Q	R	S	T	U	V
SSC8X8B	36 <sup>1</sup> / <sub>2</sub>	54 <sup>13</sup> / <sub>16</sub>	8	23 <sup>1</sup> / <sub>4</sub>	11	3 <sup>3</sup> / <sub>8</sub>	9 <sup>1</sup> / <sub>2</sub>	8	8 <sup>3</sup> / <sub>8</sub>
SSC10X10C	43 <sup>1</sup> / <sub>2</sub>	67 <sup>7</sup> / <sub>16</sub>	10	31 <sup>7</sup> / <sub>8</sub>	19 <sup>11</sup> / <sub>16</sub>	3 <sup>3</sup> / <sub>8</sub>	9 <sup>1</sup> / <sub>2</sub>	8	7 <sup>5</sup> / <sub>8</sub>

(BEARING ANALYSIS REQUIRED BY VAUGHAN ON ALL MOTORS PRIOR TO FINAL SELECTION)

HP	RPM	FRAME	L	M	W
20-40	870	320TY	38	25 <sup>1</sup> / <sub>2</sub>	17 <sup>1</sup> / <sub>8</sub>
30-60	1170				
50-125	870	360TY	43 <sup>1</sup> / <sub>4</sub>	32 <sup>3</sup> / <sub>8</sub>	17 <sup>1</sup> / <sub>8</sub>
75-125	1170				

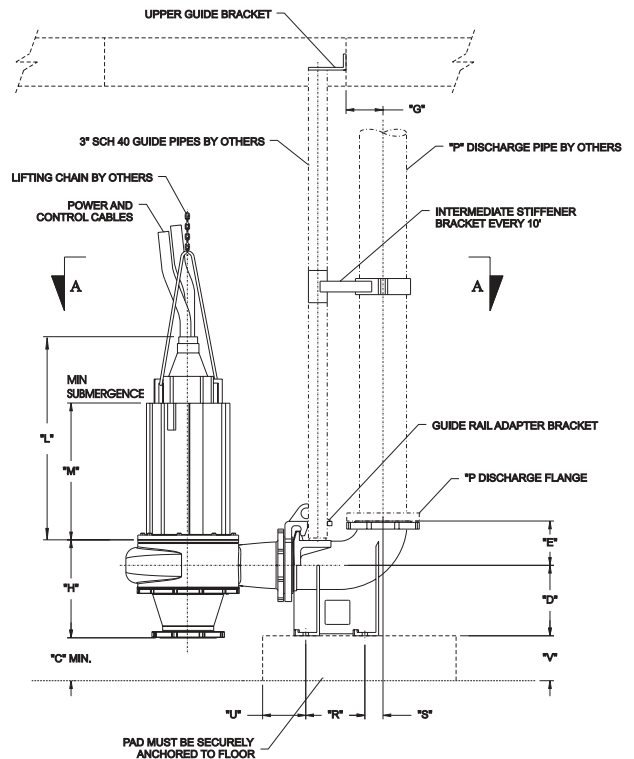

### Vaughan Co., Inc.

364 Monte Elma Road  
Montesano, WA 98563

Phone: 360-249-4042, FAX: 360-249-6155

e-mail: info@chopperpumps.com

U.S. PATENTS: No. 5,460,482; No. 5,460,483; No. 5,456, 580; No. 5,076,757; No. 3,155,046; No. 3,973,866; No. 3,774,323; No. 4,840,384; No. 4,842,479. FOREIGN PATENTS: No. 94/7561; No. 1,274,886; No. 910.127; No. 698,327; No. 1,040,006; No. 178,507; No. 539,722; No. 1,531,025; No. 1,193,483; No. 1,193,484; No. 1,193,485; No. 1,193,486; No. 498,063; No. P26 18 559; No. 512,380; No. 1,172,906; No. 963,918; No. 1,290,981; No. 687476; No. 276224; No. 75,941; No. 3480. OTHER U.S. AND FOREIGN PATENTS PENDING.

## SPECIFICATIONS - SUBMERSIBLE SCREW CENTRIFUGAL PUMPS

The Vendor shall furnish (\_\_\_) submersible, screw-centrifugal pump(s) and all appurtenances as specified. The pump(s) shall be of heavy-duty construction intended for services requiring reliable solids handling, gentle pumping action, high efficiency, and low NSPH<sub>R</sub>. Pump shall be manufactured by Vaughan Co., Inc.

### DETAILS OF CONSTRUCTION

- A. Casing and Back Pull-Out Adapter Plate: The pump casing shall be centerline discharge spiraling outward to an ANSI 150 lb. flange. Back pull-out adapter plate shall allow removal of pump components from behind the casing, and allow external adjustment of impeller-to-suction cone clearance. The casing and the adapter plate shall be ductile cast iron with all water passages to be smooth, and free of blowholes and imperfections for good flow characteristics. The backplate shall include an angled "internal cutter" groove to channel away fiber from behind the impeller.
- B. Inlet Suction Cone: The inlet suction cone shall be ductile cast iron with all water passages to be smooth, and free of blowholes and imperfections for good flow characteristics. The suction cone shall incorporate a spiral groove to channel into the casing trapped fiber that would otherwise bind between the impeller OD and the inlet cone ID.
- C. Impeller: Shall be open channel, screw-centrifugal type with pump out vanes to reduce seal area pressure. The impeller shall be ductile cast iron and shall be dynamically balanced. The single-passage impeller shall combine the action of a positive displacement screw and a single-vane centrifugal impeller.
- D. Upper Cutter: Shall be threaded into the back pullout adapter plate behind the impeller, designed to cut against the impeller pump-out vanes and hub, reducing and removing stringy materials from the mechanical seal area. Upper cutter shall be cast steel heat treated to minimum Rockwell C 60.
- E. Shafting: Pump shafting shall be heat treated. The pump shaft shall directly couple to the motor shaft, with a bolt and keyway.
- F. Stainless Steel Nameplates: Shall be attached to the pump and drive motor giving the manufacturer's model and serial number, rated capacity, head, speed and all pertinent data.
- G. Submersible Motor: The submersible motor shall be U/L listed and suitable for Class I, Group D, Division I hazardous locations, rated at \_\_\_ HP, \_\_\_ RPM, \_\_\_ Volts, 60 Hertz and 3 phase, with 1.15 service factor (1.0 for Continuous In-Air) and Class F insulation. Motor shall have tandem mechanical seals in oil bath and dual moisture sensing probes. The lower motor seal shall be exposed only to the lubricant in the bearing housing, with no exposure to the pumpage. Motor shall include two normally closed automatic resetting thermostats connected in series and imbedded in adjoining phases. Motor frame shall be cast iron, and all hardware and shaft shall be stainless steel.
- H. Lower Mechanical Seal: Shall be 316 stainless steel pusher type with tungsten carbide faces. Seal shall be positively driven by set screws. Elastomers shall be of Buna N.
- I. Standard Guide Rail System: Provide a guide rail system consisting of two (galvanized or stainless steel) 3" SCH 40 pipe guide rails, cast ductile iron pump guide bracket and discharge elbow with mounting feet and 150 lb. flange, an upper guide rail mounting bracket and intermediate guide brackets every 10 feet.
- J. Optional Spark-Proof Guide Rail System: Provide a non-sparking guide rail system consisting of two (galvanized or stainless steel) 3" SCH 40 pipe guide rails, cast aluminum-bronze pump guide bracket, cast ductile iron discharge elbow with mounting feet and 150 lb. flange, upper guide rail mounting bracket, and intermediate guide brackets every 10 feet.
- K. Surface Preparation: SSPC-SP5 commercial sandblast, primed and finish coated with minimum 10 MDFT 316 stainless steel pigment epoxy.